



TAKAI ISHIKI



KNIFE AND SAW COMPANY

PRODUCTS CATALOGUE



KNIVES FOR TYRE INDUSTRY

Our Products are Exported to...

- | | | |
|---|--|---|
|  U.S.A. |  U.K. |  AUSTRALIA |
|  SPAIN |  ITALY |  SINGAPORE |
|  VENEZUELA |  GERMANY |  MALAYSIA |
|  BRAZIL |  HOLLAND |  SRILANKA |
|  ARGENTINA |  SOUTH AFRICA |  MYANMAR (BURMA) |
|  UGANDA |  EGYPT |  BANGLADESH |
|  TANZANIA |  U.A.E. |  INDONESIA |
|  IRAN |  SAUDI ARABIA |  YEMEN |
|  NIGERIA |  KENYA |  THAILAND |



TAKAI ISHIKI

KNIFE AND SAW COMPANY

KNIVES FOR TYRE INDUSTRIES



- BIAS CUTTERS
- SCORE SLITTER KNIVES
- VENT TRIMMING KNIVES
- AUTO SKIVER KNIVES
- STEEL CORD BLADE
- MILL KNIVES

Products Catalogue

Product Type

Banner Bias Cutting Knives

Application

Specially used in manufacturing Automobile Tyres, Truck tyres, etc. for cutting Rubber Sheets.

Standard

Our Code	OD	ID	Thick	Teeth
BC0008	94	19	0.9	19
BC0008	3.3/4"	3/4"	1/27"	19
BC0007	94	19	0.9	72
BC0007	3.3/4"	3/4"	1/27"	72
BC0026	98	25.4	1 mm	72
BC1003	105	19	1 mm	72
BC0006	95	19	0.9	60
BC0006	3.5/8"	3/4"	1/27"	60
BC2011	95	19	0.9	48
BC2011	3.5/8"	3/4"	1/27"	48
BC0004	95	19	1.0	30
BC0135	3.5/8"	19	0.9	30
BC2012	95	19	1.0	24

(Hi-Low) Tooth Profile
(Hi-Low) Tooth Profile

Typical Teeth Profile of various Bias Knives

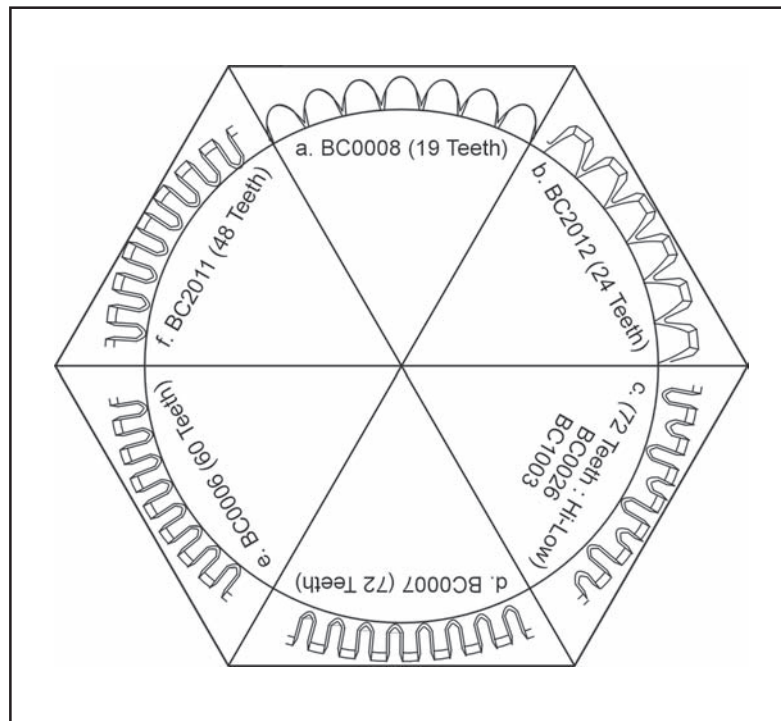

Material

AISI - D2(HCHCr) / AISI - M2 (HSS)

Also available as per customer's specific requirements. Provide your Drawings, Sample or Sketch
M: +91 9869539577 | E: takai.ishiki.knife@gmail.com

Products Catalogue

Product Type

Scoring Slitter Blades/Crush Cutter/Cameron Type Slitter

Application

Generally used for slitting/scoring the fabric in tyre industries. Also used in paper converting, Film slitting and many other application. Suitable for machines like Cameron/Arrow/Ashton/Dusenbery/Johnstone & Others.

Other Accessories

Pneumatic holder also available for score slitters. Send your sample or sketch.

Standard

Our Code	OD	ID	Thick	HUBØ
CR0059	75	19	6.35	45
CR0583	76.2	19	5.50	60
CR0023	76	22	6.35	45
CR0020	3"	3/4"	1/4"	
CR0021	3"	7/8"	1/4"	
CR0180	3"	19	1/8"	46

Various Slitters/Scorers/Crushers with cutting Angles & degree.

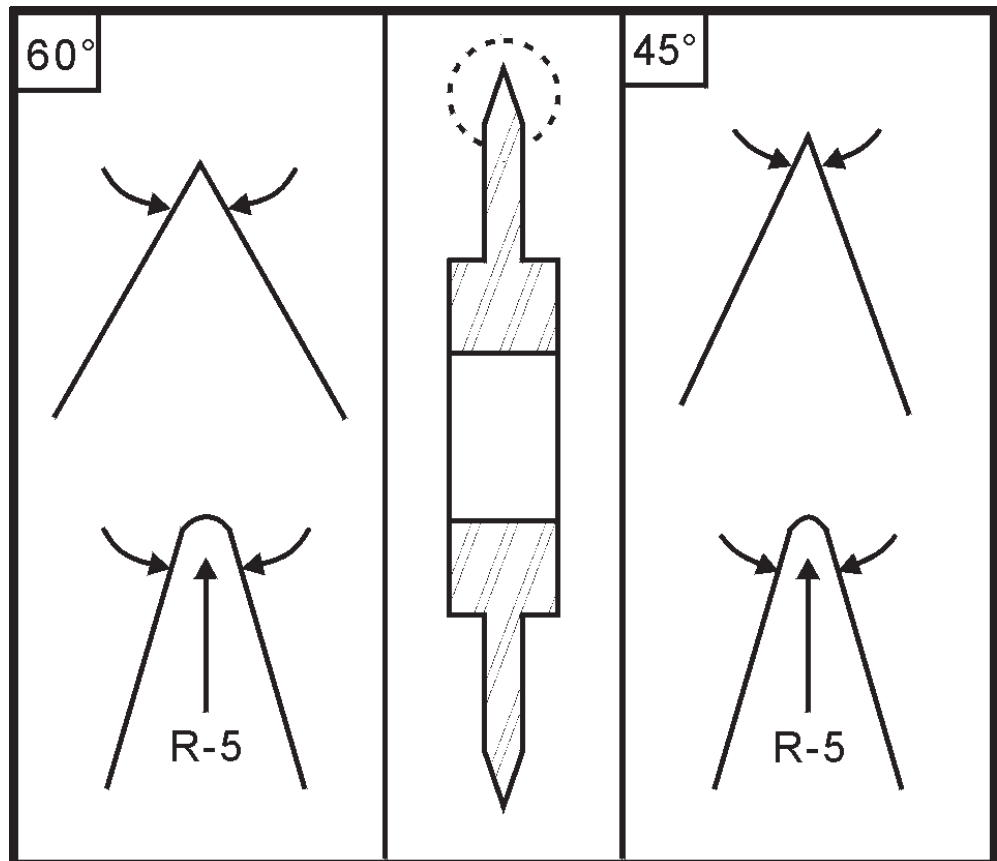

Material

SAE 52100/ AISI D2. Also available in HSS.

Also available as per customer's specific requirements. Provide your Drawings, Sample or Sketch

M: +91 9869539577 | E: takai.ishiki.knife@gmail.com

A WORLD OF EXPERIENCE IN CUTTING TOOLS

Products Catalogue

Product Type

Top Cutter / Male Knives

Application

Slitting of Paper, Film, Aluminium Foil, Rubber, Leather Cloth, etc.

Standard

The standard sizes shown in both the above tables are in millimeters. Other sizes, in Inches, can be produced or offered on request.

Top Knives - Plain Bore

D	d	Wide	Depth	Thickness	
				T1	T2
100	70	2.5	3	1.0	1.2
130	80	3.5	3.5	1.5	
130	100	3.6	4	1.5	

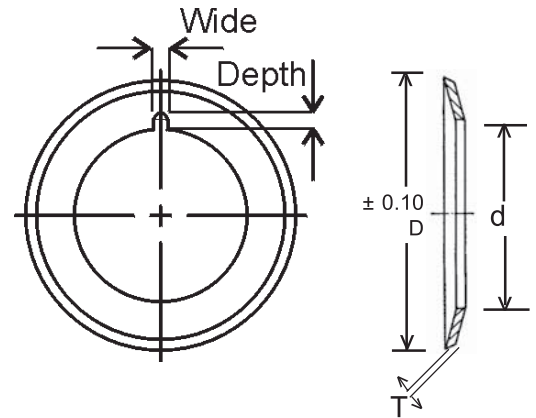

Material

SAE 52100 / AISI - D2. Also available in H.S.S.

Product Type

Bottom Cutters / Female Knives

Standard

Bottom Shear Knives / Female Knives with Plain Bore.

Our Code	OD	ID	Thickness	
			T1	T2
BO0127	80	60	3.5	5
BO0015	80	60	8	10
BO1512	105	90	8	10

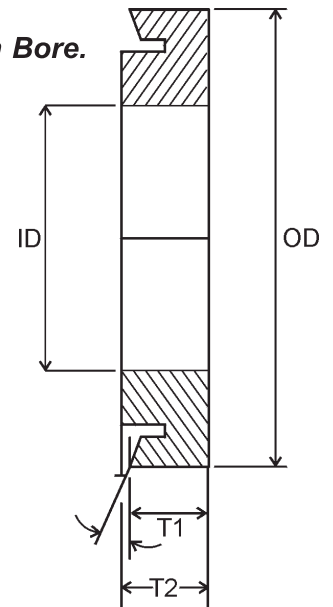

Material

SAE 52100 / AISI D2 or as per your requirements.

Also available as per customer's specific requirements. Provide your Drawings, Sample or Sketch

M: +91 9869539577 | E: takai.ishiki.knife@gmail.com

A WORLD OF EXPERIENCE IN CUTTING TOOLS

Products Catalogue

Product Type

Vent Trimming Blades

Application

Used exclusively in tyre manufacturing industry and tyre remoulding industries to trim the vents on the fabricated tyres after it comes out of moulding.

Standard

Our Code	L	W	T	No. of Grooves
VT001	1.7/8"	2"	0.083"	9
VT007	47 mm	50 mm	2.1 mm	9
VT0012	3"	2"	0.083"	14
VT0013	75	50	2.0	14

Typical line sketches of various Vent Trimming Knives used in Tyre Manufacturing Industries

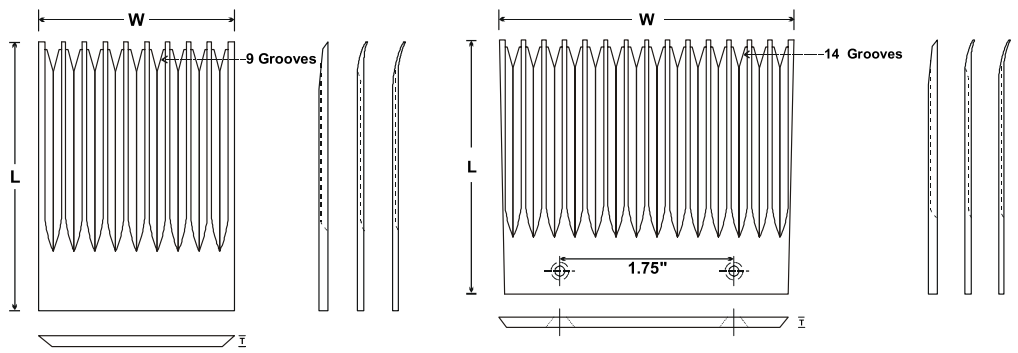

Material

AISI - D2. Also available in HSS

Product Type

Mill Knives

Standard

L	W	T
6"	1"	1/8"
6"	1"	1/4"
8"	1"	1/8"
8"	1"	1/4"
152	25	3
152	25	6
200	25	3
200	25	6
200	35	15
200	40	3.0

With or without holes.

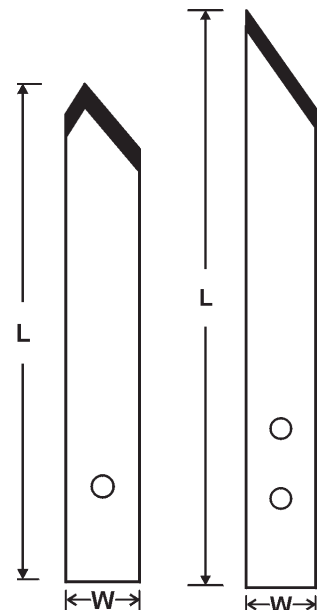

Material

AISI - D2. Also available in HSS

Also available as per customer's specific requirements. Provide your Drawings, Sample or Sketch

M: +91 9869539577 | E: takai.ishiki.knife@gmail.com

Products Catalogue

Product Type

Spadone Tread Knives / Auto Skiver Blades

Application

Used in cutting Rubber in Tyre manufacturing Industries on auto skiver machines.

Standard

Our Code	OD	ID	Thick
AT5012	20"	2.75"	0.25"
AT5005	20"	2.75"	4.5 mm
AT5004	505 mm	70	6 mm
AT 6001	600 mm	35	1/4"
AT 2001	10"	5/8"	3/32"
AT4003	400	50	5 mm
AT 4001	17"	60	0.15"
AT 4002	17"	2.5"	0.15"

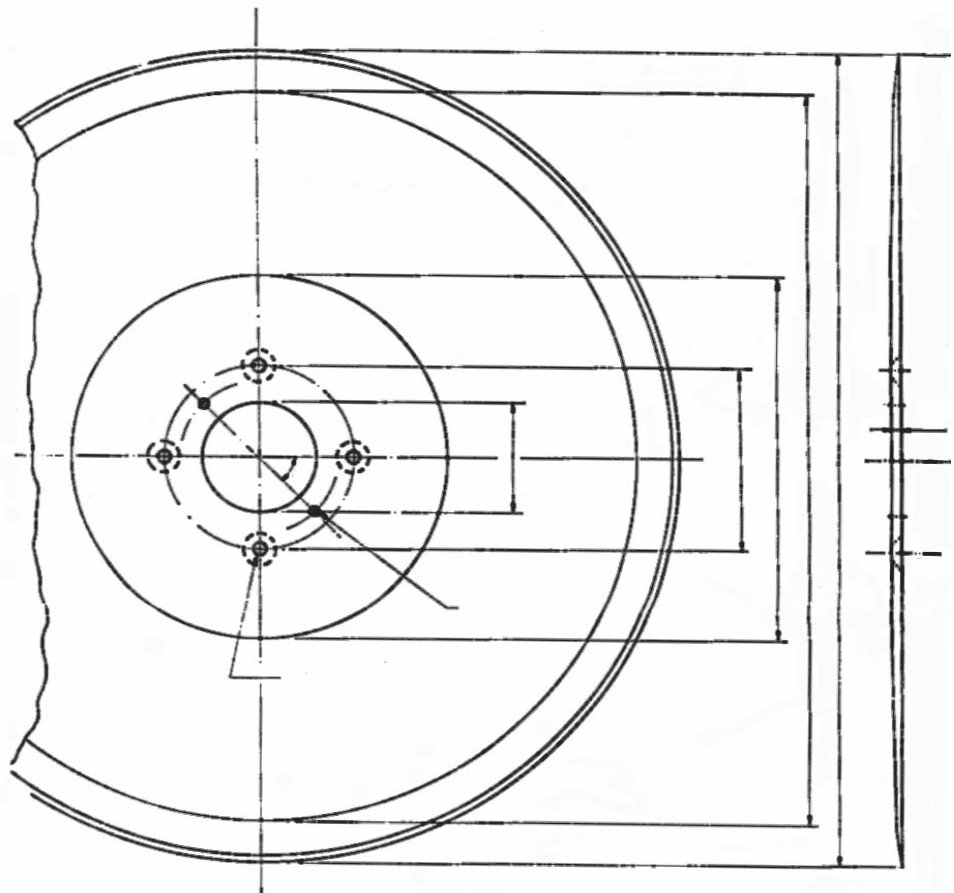

Material

AISI - D2. Also available in HSS

Also available as per customer's specific requirements. Provide your Drawings, Sample or Sketch
M: +91 9869539577 | E: takai.ishiki.knife@gmail.com

A WORLD OF EXPERIENCE IN CUTTING TOOLS

Products Catalogue

Product Type

Steel Cord Blade

Application

For cutting steel Reinforced Rubber generally used in Radial Tyre Plant.

Standard

Size upto 4 Mtr. long.



Material

AISI-D2 or carbide inserted as per drawing.

Product Type

Other Knives

Any other Knives which are not shown here like Band Building Knives, Calender Knives, other types of slitting knives, etc. are also available or can be produced as per the drawing / specifications / samples of the customer.

Our Products at a Glance - Listed Industry Wise for EXPORTS

A. Tyre Industries:

1. Bias Cutter,
2. Vent Trimming Knives,
3. Tread Cutters, Auto Skiver Blades,
4. Scoring/Slitting Knives,
5. Mill Knives - Straight & Round,
6. Steel Cord Knives.

B. Wood Working Industries:

1. Peeling Knives for Plywood Mills,
2. Jointer Knives,
3. Pressure Bars,
4. Tungsten Carbide Tipped Saws,
5. Slicer Knives,
6. Clipper Knives,
7. Band Saw Blades upto 6" width.

C. Cigarette & Tobacco Industry:

1. MRTC Knives,
2. Hauni Knives - & MILI Knives,
3. Wafer Knives,
4. Filter Cutting Knives,
5. Ripper Knives,
6. Foil Slitter Knives,
7. Plug cutting Knives,
8. Creasing & Cutting Knives and Anvils,
9. Leaf & Steam Cutting Knives,
10. Carbides Knives for Paper Cutting.

D. Match Stick Manufacturing Industries:

1. Peeling Knives,
2. Chopping Knives,
3. Lancets (Choping, Angular, etc.),
4. Creasing & Cutting Knives and Anvils,
5. Circular Slitting Knives for Match Box.

E. Paper Converting Industries:

1. Circular Slitter Knives, (Top cutters, Bottom Cutters & Holders for Top Cutters),
2. Crush Cutter Knives and pneumatic holders
3. Core Cutters,
4. Razor Type Knives,
5. Sheeter Knives,
6. Paper Cutting Knives,
7. Doctor Blades
8. Web press serrated knives.

F. Paper and Pulp Industries:

1. Chipper Knives (Fly and Dead),
2. Sheet Cutting Knives,
3. Guillotine Knives (Paper Cutting Knives),
4. Top Cutters - Bottom Cutters
5. Doctor Blades.

G. Cotton Industries:

1. Ginning Saws,
2. Linter Saws.

H. Asbestos Sheet Making Industries:

1. Circular Knives for Asbestos Sheet Cutting in wet conditions - Material of Construction - Alloy Steel or Carbide Segmented.

I. Recycling Industries:

1. Granulator Knives (Rotor and Stator Type),
2. Scrap Cutting Knives,
3. Tungsten Carbide Tipped Saws,
4. Friction Saws,
5. Rotary Cutter for Granules.

J. Leather Industries:

1. Strap Cutting Knives,
2. All types of Straight and circular Knives,
3. Splitting Knives,
4. Band Knives.

K. Polyester Fibre Industries:

1. Lummus Blades.

L. Food Industries:

1. Circular Slicing Knives,
2. Chopping Knives,
3. Other Special Knives from Stainless Steel.

M. Clothing Industries:

1. Circular Knives,
2. Codoroy Cutting Blade Set,
3. Plush Cutting Blade fro Velvet Industries.

N. Metal Industries-Steel Plant & Rolling Mills:

1. Shearing Blades upto 4 meter long,
2. Circular Rotary Knives for Slitting,
3. Fins & Spacers,
4. HSS Cobra Saws
5. Tube parting of Blades & C.O.C. Cutters
6. Carbide Tipped Slitting Saws for Grooving, Milling and Slotting,
7. H.S.S. Metal Slitting Saws,
8. H.S.S. & Carbide Small Tools like Drills Endmills, Side and Face Cutter and Similar other Tools.

O. Standard Tools:

1. HSS Ground Square and Ground Tool Bits,
2. Flat/Rectangular and Parting Tool Bits,
3. Twist Drills,
4. Wood Working Drills,
5. Masonry Drills,
6. Hole Saws.

ALSO AVAILABLE AS PER CUSTOMER'S SPECIFIC REQUIREMENTS. PROVIDE YOUR DRAWINGS, SAMPLE OR SKETCH

Exported by :

**TAKAI ISHIKI
KNIFE AND SAW COMPANY**



Gala No.5, Patel Industrial Estate No.2, Near Fire Brigade, Navghar, Vasai East 401208.
M: +91 9869539577 | E: takai.ishiki.knife@gmail.com