



TAKAI ISHIKI















KNIFE AND SAW COMPANY

PRODUCTS CATALOGUE



KNIVES FOR CONVERTING INDUSTRY

Our Products are Exported to...

- | | | |
|---|--|---|
|  U.S.A. |  U.K. |  AUSTRALIA |
|  SPAIN |  ITALY |  SINGAPORE |
|  VENEZUELA |  GERMANY |  MALAYSIA |
|  BRAZIL |  HOLLAND |  SRILANKA |
|  ARGENTINA |  SOUTH AFRICA |  MYANMAR (BURMA) |
|  UGANDA |  EGYPT |  BANGLADESH |
|  TANZANIA |  U.A.E. |  INDONESIA |
|  IRAN |  SAUDI ARABIA |  YEMEN |
|  NIGERIA |  KENYA |  THAILAND |



TAKAI ISHIKI

KNIFE AND SAW COMPANY

KNIVES FOR CONVERTING INDUSTRIES



- TOP CUTTERS / HOLDERS
- BOTTOM CUTTERS
- CIRCULAR SLITTERS
- PAPER CUTTING KNIVES
- SHEET CUTTING KNIVES
- WEB PRESS SERRATED KNIVES

Products Catalogue

Product Type

Application

Standard

The standard sizes shown in both the above tables are in millimeters. Other sizes, in Inches, can be produced or offered on request.

Top Cutter / Male Knives

Slitting of Paper, Film, Aluminium Foil, Rubber, Leather Cloth, etc.

Top Knives - Plain Bore

D	d	Wide	Depth	Thickness			
				T1	T2	T3	T4
62	40	2.5	3	0.6	0.8	1.0	1.2
65	40	4.0	3	0.8	1.0		
68	40	2.5	3	1.0	1.2		
68	45	3	3	1.0	1.2		
75	50	3/16	3/16	1.0	1.2		
89	60	3	3.5	0.8	1.0	1.2	
90	60	3	5	1.0	1.2		
100	70	2.5	3	1.0	1.2		
105	65	4	5	0.8	1.0	1.2	
105	70	3	4	0.8	1.0	1.2	
105	75	3.5	4	0.8	1.0	1.2	
108	65	4	5	1.0	1.2		
108	75	4	5	1.0	1.2		
110	65	4	4	1.0	1.2		
110	70	4	4	1.0	1.2		
110	75	4	4	1.0	1.2		
130	80	3.5	3.5	1.5			
130	100	3.6	4	1.5			
200	65	20		2.0	3.5	3.0	

Top Knives - Bayonet Bore

D	d	Wide	Depth	Thickness		
				T1	T2	T3
64	38	2.5	3.0	1.0	1.2	
68	40	2.5	3.0	0.6	1.0	
75	40	3.0	3.0	1.2		
89	55	4.0	5.0	0.8	1.0	1.2
90	55	4.0	4.0	1.2		
100	65	4.0	4.0	0.8	1.0	1.2
105	65	4.0	4.0	0.8	1.0	1.2
108	65	4.0	4.0	1.0	1.2	
130	80	4.0	4.0	1.0	1.5	
140	80	4.5	5.0	1.5		
150	90	4.5	5.0	1.5		

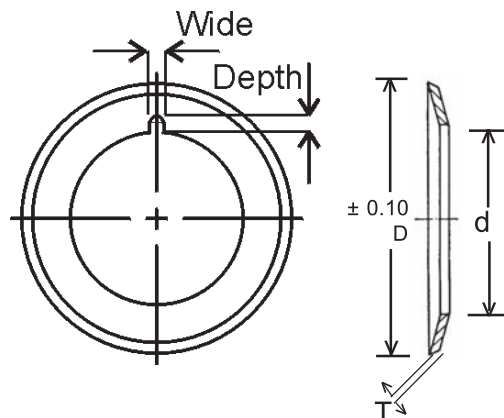
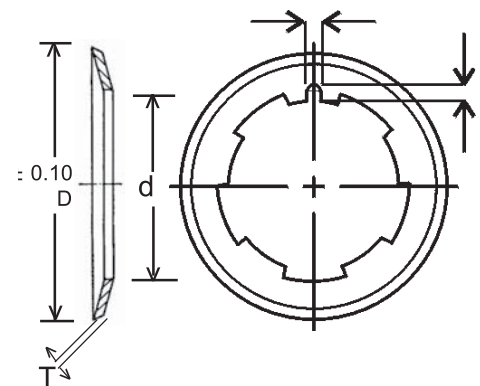

Various Cutting Angles

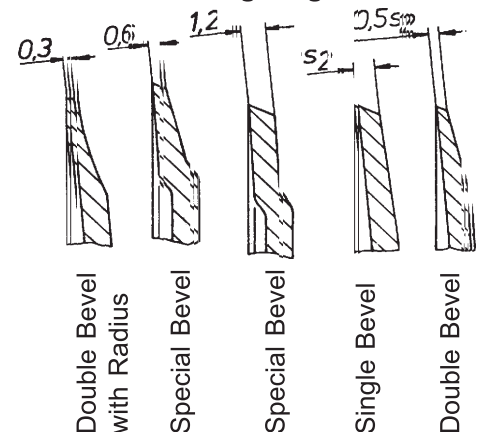

Material

SAE 52100 / AISI - D2. Also available in H.S.S.

Also available as per customer's specific requirements. Provide your Drawings, Sample or Sketch

M: +91 9869539577 | E: takai.ishiki.knife@gmail.com

Products Catalogue

Product Type

Application

Standard

Holders / Top Knives Adapter

This is only as adapter to Top Cutters.

Available in different sizes to suit various locking arrangements.

Our Code	W	H	Thick.	Shaft Locking
HO0008	77	45	10 mm	with key
HO0011	77	35	10 mm	with key
HO0016	77	50.8	10 mm	with key
HO0002	85	60	15 mm	with ball bearing
HO0080	75	45	15 mm	with key
HO0059	90	60	15 mm	with ball bearing
HO0003	90	60	10 mm	with ball bearing
HO1002	112.5	80	20 mm	with key
HO0026	50	20	26.5 mm	with key
HO0024	56	30	25.0 mm	with key

With spring circlip and key, wherever required.

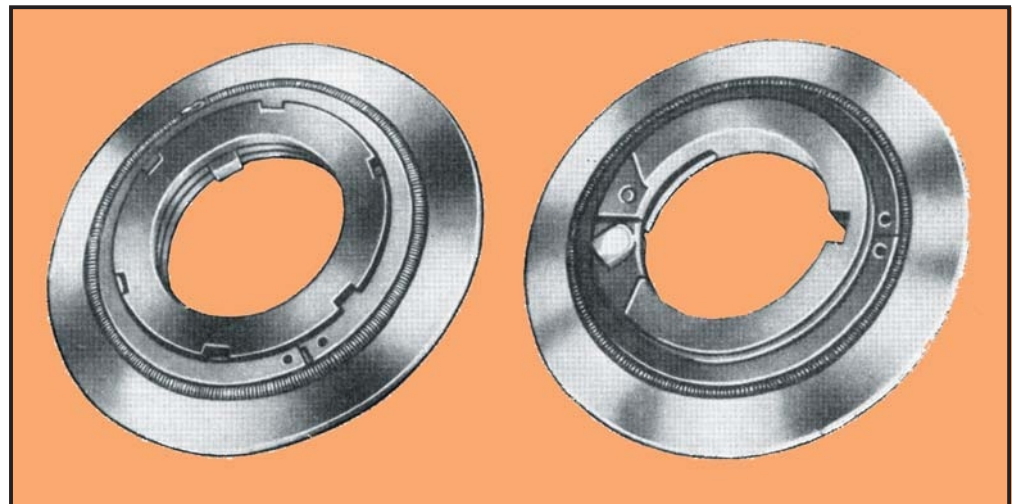

Also available with Ball Bearing Type self-locking arrangement.

Also available as per customer's specific requirements. Provide your Drawings, Sample or Sketch
M: +91 9869539577 | E: takai.ishiki.knife@gmail.com

A WORLD OF EXPERIENCE IN CUTTING TOOLS

Products Catalogue

Product Type

Standard

Bottom Cutters / Female Knives

Bottom Shear Knives / Female Knives with Plain Bore.

Our Code	OD	ID	Thickness	
			T1	T2
BO0025	46	25	2.5	4
BO0029	60	40	4	6
BO0032	60	40	8	10
BO0010	75	45	4	6
BO0002	75	50	4	6
BO0053	77	60	8	10
BO0127	80	60	3.5	5
BO0015	80	60	8	10
BO0062	98	38	12	14
BO1020	180	50	25	
BO1007	200	145	25	

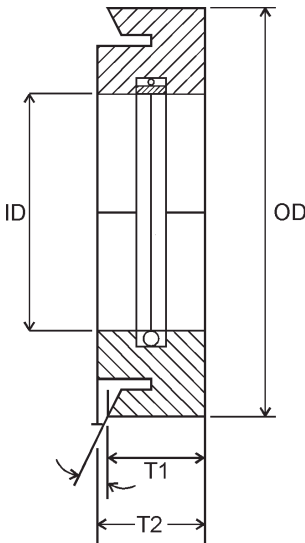
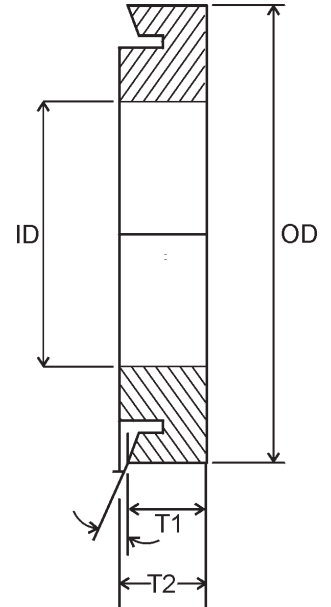

Bottom Shear Knives / Female Knives with Self-locking Type. (with Ball Bearing Balls)

Our Code	OD	ID	Thickness	
			T1	T2
BO0048	77	45	11.7	14.75
BO0068	77	45	13	15
BO0015	80	60	8	10
BO1512	105	90	8	10
BO1015	108	50.8	10	12.65

Multi Block Bottom Shear Knives

- Size 1 160 Ø
 - Size 2 180 Ø
 - Size 3 200 Ø
- } With 5 Grooves
or 10 Grooves

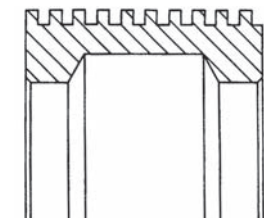

Material

SAE 52100 / AISI D2 or as per your requirements.

Also available as per customer's specific requirements. Provide your Drawings, Sample or Sketch

M: +91 9869539577 | E: takai.ishiki.knife@gmail.com

A WORLD OF EXPERIENCE IN CUTTING TOOLS

Products Catalogue

Product Type

Circular Knives

Application

Wudtools offers a complete range of Circular Knives for varied applications industry wise. Hundreds of sizes, many from stock. Our range starts from 25 mm Ø to 500 mm Ø (1" Ø to 20" Ø) in various forms, various cutting angles, with or without perforations.

Paper • Packing • Textiles • Plastic • Rubber • Film • Food Processing
• Cement Sheets, etc.

Standard

Our Code	OD	ID	Thickness
CR0015	3"	1"	1.2 mm
CR0015	75	25	1.0 mm
CR0069	80	40	1.0 mm
CR1030	4"	1"	1.2 mm
CR1050	100	25	1.0 mm
CR1004	125	25	2.0 mm
CR5006	150	30	2.0 mm
CR2014	200	40	2.4 mm
CR2019	200	40	3.5 mm
CR2018	200	65	2.0 mm
CR3003	300	90	2.0 mm



Material

SAE 52100 / AISI - D2 / AISI - M2 / Stainless Steel / Tungsten Carbide.

Also available as per customer's specific requirements. Provide your Drawings, Sample or Sketch

M: +91 9869539577 | E: takai.ishiki.knife@gmail.com

A WORLD OF EXPERIENCE IN CUTTING TOOLS

Products Catalogue

Product Type

Application

Standard

Paper Cutting Knives

For all automatic machines for extremely fine finish

As per the machines and their different models, our knives are ordered as replacement on various machines like Atlas, Como, Harris, Maxima, Perfecta, Polar, Muller-Martini, Wohlenberg, etc.

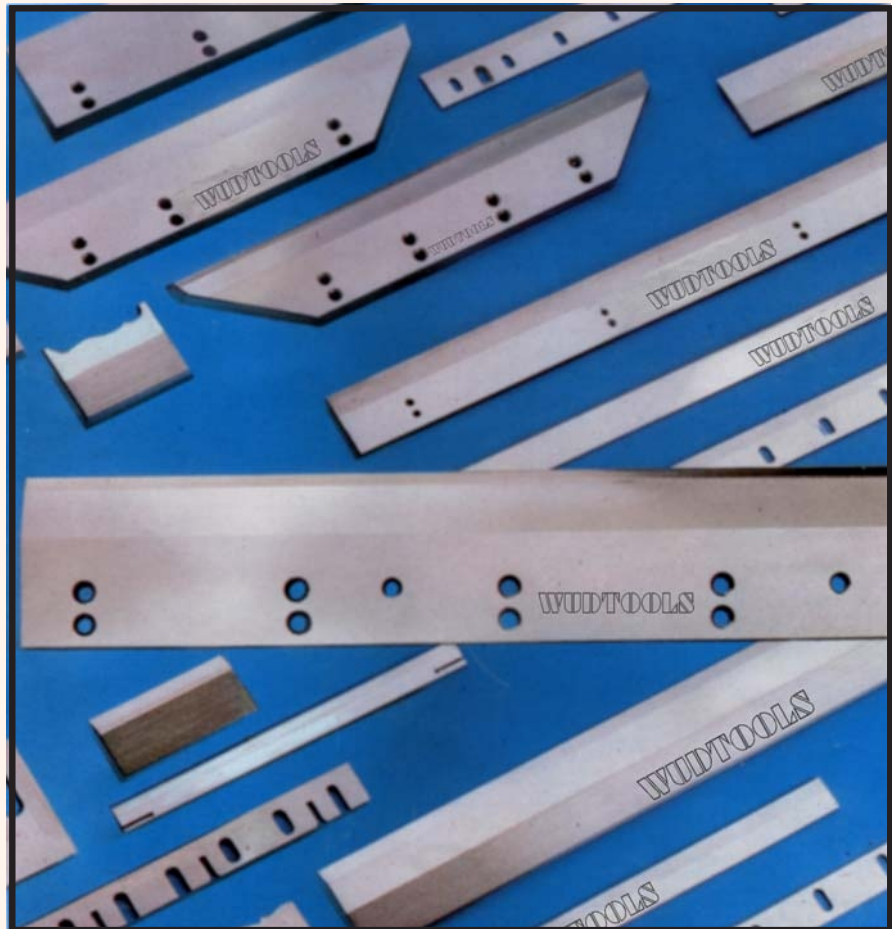

Various knives

- | | |
|--------------------|-------------------|
| ⌘ Paper Cutting | ⌘ Three knife set |
| ⌘ Trimmer Knives | ⌘ Sheeter Knives |
| ⌘ Packaging Knives | |

Material

High Carbon Steel / AISI - D2 / HSS-inlay / TC-inlaid.

Also available as per customer's specific requirements. Provide your Drawings, Sample or Sketch
M: +91 9869539577 | E: takai.ishiki.knife@gmail.com

A WORLD OF EXPERIENCE IN CUTTING TOOLS

Products Catalogue

Product Type

Sheet Cutters

Application

Generally used in the Paper Mills for cut-to-length Paper Sheets. Wudtools range starts from 500 mm (20") to 4000 mm (160") with various types of cutting Angles.

Standard

We have capacity to produce sheet cutter upto 4 meters in length.

Depending upon the requirement of the customer, to their drawing, this is manufactured.

Material

AISI - D2

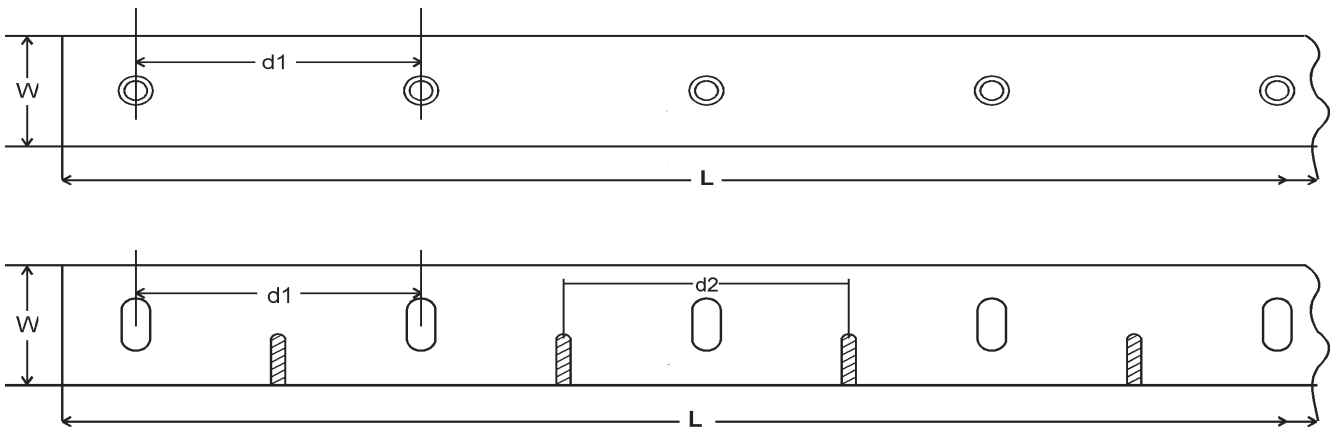

Also available as per customer's specific requirements. Provide your Drawings, Sample or Sketch
M: +91 9869539577 | E: takai.ishiki.knife@gmail.com

A WORLD OF EXPERIENCE IN CUTTING TOOLS

Products Catalogue

Product Type

High Quality Web Press Serrated Cut-off Knives for every Machine

Wudtools worldwide, provides web press serrated edge cut-off knives. You name it, we can provide it. Whether your press is domestic or foreign built, you can always count on us for availability, fast response, and performance.



Standard

- ② Machined and precision ground to OEM specifications.
- ② From ground tooth profiles assure consistent size and burr-free cutting edges.
- ② Tooth forms in Rip Saws, V-Tooth and Herringbone styles serrated and bevelled, on one or both sides.
- ② Over 40 types in 8, 10, 12 and 16 teeth per inch.
- ② Custom designs manufactured to order.

Also included in our programme are :

- ② Standard or Split Perforators
- ② Rotary cut-off Blades

<ul style="list-style-type: none"> ② ATF ② Baker Perkins ② Butler ② Cerutti ② Hantscho ② Harris ② Miehle-Goss ② Motter ② Toshiba ② Wood-Hoe, and others. ② Custom-Built 	
--	--

Special sizes and custom knives are made to your specifications. Firm prices and prompt deliveries are offered by us.

Also available as per customer's specific requirements. Provide your Drawings, Sample or Sketch
M: +91 9869539577 | E: takai.ishiki.knife@gmail.com

Products Catalogue

Product Type

Asbestos Cutting Knives of Steel

Application

Wet Asbestos Cement Sheet cutting.

We are one of the pioneers in traditional Alloy steel knives for wet Asbestos Cement Sheet cutting. We can offer the same in HSS and High Carbon high Chromium Steel (C = 2.1, Cr = 12%).

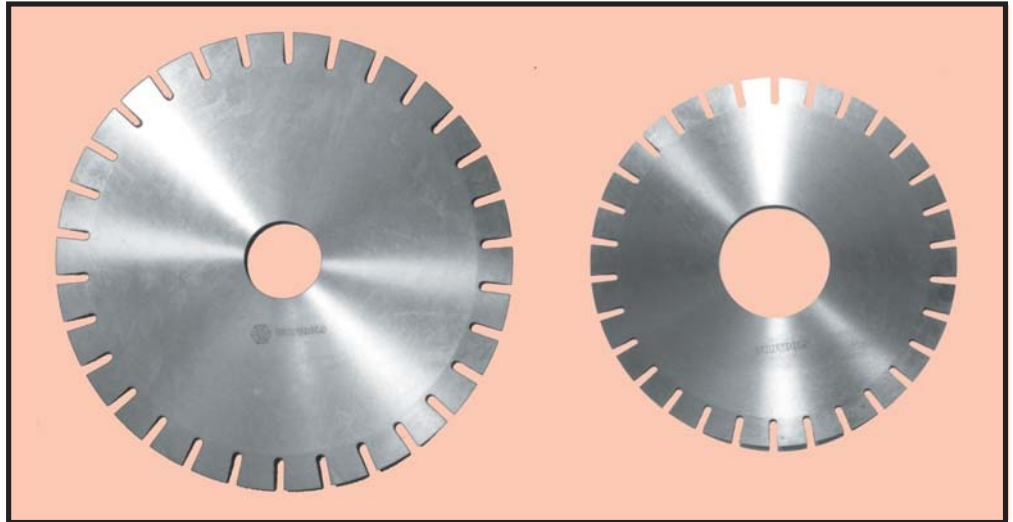

Standard

Following are some of the common sizes but we can make any size required.

Our Code	Sizes of Circular Knives for Asbestos Sheet Industries
CR2056	250 od x 50 id x 3 mm thick x 30 teeth
CR2061	250 od x 60 id x 2 mm thick x 30 teeth
CR3009	300 od x 30 id x 2 mm thick x 30 teeth
CR3038	300 od x 30 id x 3 mm thick x 24 teeth
CR3010	300 od x 35 id x 2 mm thick x 30 teeth
CR3011	300 od x 50 id x 2 mm thick x 30 teeth
CR3004	300 od x 55 id x 2 mm thick x 36 teeth
CR3003	300 od x 90 id x 2 mm thick x 30 teeth
CR3032	300 od x 90 id x 3 mm thick x 30 teeth
CR3045	300 od x 90 id x 2 mm thick (without teeth)

Material

AISI D2 (HCHCr) / AISI M2 (HSS)

Also available as per customer's specific requirements. Provide your Drawings, Sample or Sketch
M: +91 9869539577 | E: takai.ishiki.knife@gmail.com

Products Catalogue

Product Type

Asbestos Cutting Knives from Tungsten Carbide Segments

Application

Wudtools's 'Carbcut' Carbide Segmented Bevel Knives have been developed over a number of years and have an excellent and proven track record. The circular knife consists of a steel body plat fitted with bevel edge tungsten carbide segments - each segment being pinned for increased operating safety.

Wudtools's Hard Metal Division, recommend that the maximum operating speed as 4000 rpm, although each blade is test run at speeds of 6000 rpm prior to despatch.

'Carbcut' Carbide Knives are primarily designed for the cutting of asbestos and its substitute, a wet fibre cement, plus a wide range of other composite boards and panels.

Also in the new development made by our hard metal division now we can also offer you the complete ring configuration specially for wet fibre cement and composite boards. This will substitute the configuration of Carbide Segment with One Carbide Ring configuration.

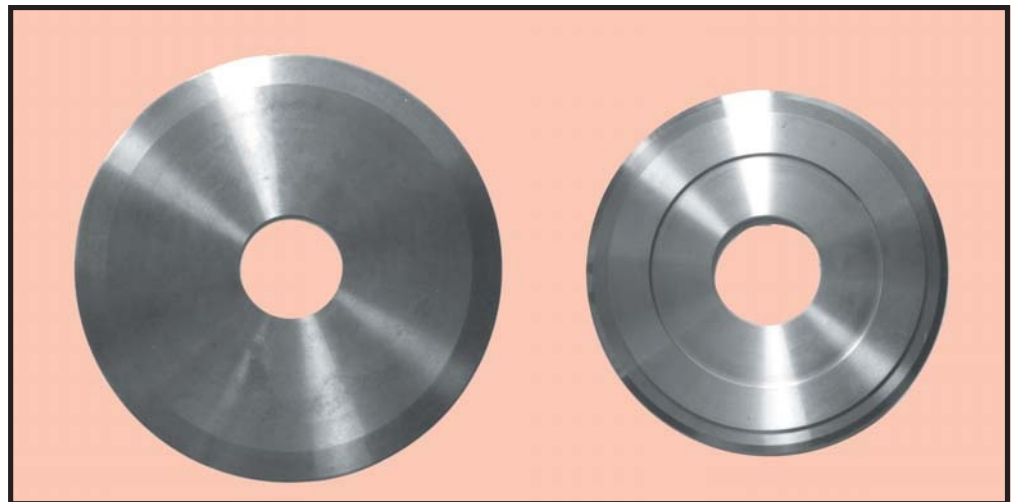

Standard

Our Code	Sizes of Asbestos Sheet Cutting Knives with Carbide Segments
	300 od x 50 id x 2.2/28mm thick x 18 segment
	300 od x 50 id x 2.2/28mm thick x 10 segment
	300 od x 50 id x 2.2/28mm thick x 1 ring

Material

Tungsten Carbide.

Also available as per customer's specific requirements. Provide your Drawings, Sample or Sketch
M: +91 9869539577 | E: takai.ishiki.knife@gmail.com

Products Catalogue

Product Type

Application

Industrial & Utility Razor Knives

Wudtools provides various special blades and knives that find applications in hundreds of industries as well as in handicraft and utility gadgets.

Wudtools provides 'technical' blades for production, cutting and slitting of plastic films, rubber products, textiles, fibres, leather, glassware, cardboard, paper, web cut-off, packaging, pencil sharpeners, etc. However, we provide special blades for applications that fall outside the standard range.

Blades illustrated in this catalogue are produced with "hair cutting sharpness". You will find most of your applications in this catalogue and we will be happy provide them require your consolidated schedule of requirement for regular supplies.

Call on us with specific application, quantities and details of what you are using presently. We will try to give you your exact requirement or help you to choose from our nearest standards so that you can always procure them easily from us.

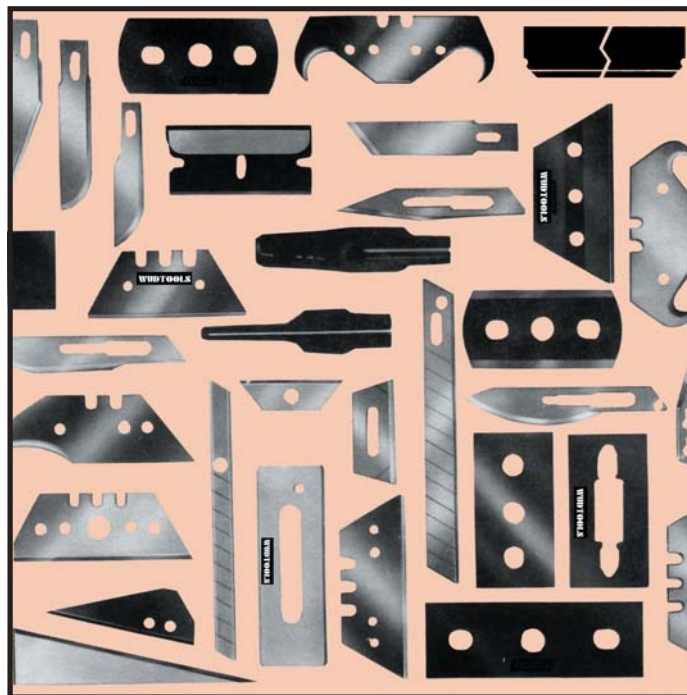

Various Industrial Razor Knives :

- Three Hole Blades
- Oblong Hole Blade
- Vallet Blade
- Triangular Blade
- Snap of Blade
- Lummus - Mark IV
- Lummus - Mark V
- Glass Fibre Blade 197 mm long
- Glass Fibre Blade 137 mm long

Also available as per customer's specific requirements. Provide your Drawings, Sample or Sketch
M: +91 9869539577 | E: takai.ishiki.knife@gmail.com

A WORLD OF EXPERIENCE IN CUTTING TOOLS

Our Products at a Glance - Listed Industry Wise for EXPORTS

A. Tyre Industries:

1. Bias Cutter,
2. Vent Trimming Knives,
3. Tread Cutters, Auto Skiver Blades,
4. Scoring/Slitting Knives,
5. Mill Knives - Straight & Round,
6. Steel Cord Knives.

B. Wood Working Industries:

1. Peeling Knives for Plywood Mills,
2. Jointer Knives,
3. Pressure Bars,
4. Tungsten Carbide Tipped Saws,
5. Slicer Knives,
6. Clipper Knives,
7. Band Saw Blades upto 6" width.

C. Cigarette & Tobacco Industry:

1. MRTC Knives,
2. Hauni Knives - & MILI Knives,
3. Wafer Knives,
4. Filter Cutting Knives,
5. Ripper Knives,
6. Foil Slitter Knives,
7. Plug cutting Knives,
8. Creasing & Cutting Knives and Anvils,
9. Leaf & Steam Cutting Knives,
10. Carbides Knives for Paper Cutting.

D. Match Stick Manufacturing Industries:

1. Peeling Knives,
2. Chopping Knives,
3. Lancets (Choping, Angular, etc.),
4. Creasing & Cutting Knives and Anvils,
5. Circular Slitting Knives for Match Box.

E. Paper Converting Industries:

1. Circular Slitter Knives, (Top cutters, Bottom Cutters & Holders for Top Cutters),
2. Crush Cutter Knives and pneumatic holders
3. Core Cutters,
4. Razor Type Knives,
5. Sheeter Knives,
6. Paper Cutting Knives,
7. Doctor Blades
8. Web press serrated knives.

F. Paper and Pulp Industries:

1. Chipper Knives (Fly and Dead),
2. Sheet Cutting Knives,
3. Guillotine Knives (Paper Cutting Knives),
4. Top Cutters - Bottom Cutters
5. Doctor Blades.

G. Cotton Industries:

1. Ginning Saws,
2. Linter Saws.

H. Asbestos Sheet Making Industries:

1. Circular Knives for Asbestos Sheet Cutting in wet conditions - Material of Construction - Alloy Steel or Carbide Segmented.

I. Recycling Industries:

1. Granulator Knives (Rotor and Stator Type),
2. Scrap Cutting Knives,
3. Tungsten Carbide Tipped Saws,
4. Friction Saws,
5. Rotary Cutter for Granules.

J. Leather Industries:

1. Strap Cutting Knives,
2. All types of Straight and circular Knives,
3. Splitting Knives,
4. Band Knives.

K. Polyester Fibre Industries:

1. Lummus Blades.

L. Food Industries:

1. Circular Slicing Knives,
2. Chopping Knives,
3. Other Special Knives from Stainless Steel.

M. Clothing Industries:

1. Circular Knives,
2. Codoroy Cutting Blade Set,
3. Plush Cutting Blade fro Velvet Industries.

N. Metal Industries-Steel Plant & Rolling Mills:

1. Shearing Blades upto 4 meter long,
2. Circular Rotary Knives for Slitting,
3. Fins & Spacers,
4. HSS Cobra Saws
5. Tube parting of Blades & C.O.C. Cutters
6. Carbide Tipped Slitting Saws for Grooving, Milling and Slotting,
7. H.S.S. Metal Slitting Saws,
8. H.S.S. & Carbide Small Tools like Drills Endmills, Side and Face Cutter and Similar other Tools.

O. Standard Tools:

1. HSS Ground Square and Ground Tool Bits,
2. Flat/Rectangular and Parting Tool Bits,
3. Twist Drills,
4. Wood Working Drills,
5. Masonry Drills,
6. Hole Saws.

ALSO AVAILABLE AS PER CUSTOMER'S SPECIFIC REQUIREMENTS. PROVIDE YOUR DRAWINGS, SAMPLE OR SKETCH

Exported by :

**TAKAI ISHIKI
KNIFE AND SAW COMPANY**



Gala No.5, Patel Industrial Estate No.2, Near Fire Brigade, Navghar, Vasai East 401208.
M: +91 9869539577 | E: takai.ishiki.knife@gmail.com